

198 WATT

HIGH-POWER. EFFICIENT INSTALLATION.

POLYCRYSTALLINE SILICON PHOTOVOLTAIC MODULE WITH 198W MAXIMUM POWER

These polycrystalline 198 watt modules offer high-powered performance with an efficient design for quick and easy installation. For use specifically with Sharp's solar racking system (SRS), they are designed to offer easier and faster installations. Using breakthrough technology perfected by Sharp's more than 50 years of research and development, these modules use a textured cell surface to increase light absorption and improve efficiency. Ideal for virtually all sizes of residential and commercial grid-connected systems, they also offer improved aesthetics and durability under the most rigorous operating conditions. Sharp's ND-198U1F modules are the ideal combination of power, performance and efficiency.



FEATURES

- High-power module (198W) using 156mm square polycrystalline silicon solar cells with 13.4% module conversion efficiency
- Sharp's advanced surface texturing process increases light absorption and efficiency while providing a more subdued, "natural" look
- Bypass diodes minimize the power drop caused by shade
- Black anodized aluminum frame and "L" hook design located along frame perimeter for easy integration with SRS mounting hardware
- Water white tempered glass, EVA resin, and a weatherproof film, plus aluminum frame for extended outdoor use
- UL Listings: UL1703, cUL
- Sharp modules are manufactured in ISO 9001 certified facilities
- 25-year limited warranty on power output (see dealer for details)



Special side flanges mount easily and securely to Sharp's innovative solar racking system



Sharp RESIDENTIAL SYSTEM modules offer outstanding performance for a variety of applications.

ELECTRICAL CHARACTERISTICS

Cell	Polycrystalline silicon
No. of Cells and Connections	54 in series
Open Circuit Voltage (Voc)	32.9V
Maximum Power Voltage (Vpm)	26.3V
Short Circuit Current (Isc)	8.23A
Maximum Power Current (Ipm)	7.52A
Rated Power (Pm)*	198W (+10% / -5%)
Module Efficiency	13.4%
Maximum System Voltage	600V
Series Fuse Rating	15A
Type of Output Terminal	Lead Wire with MC Connector

* (STC) Standard Test Conditions: 25°C, 1 kW/m², AM 1.5

MECHANICAL CHARACTERISTICS

Dimensions (A x B x C below)	39.1" x 58.7" x 2.3" (994mm x 1491mm x 57.5mm)
Weight	39.6 lbs / 18.0 kg
Size of Carton	59.29" x 39.76" x 5.16" (1506mm x 1010mm x 131mm)
Packing Configuration	2 pcs per carton
Pallet Quantity	30 pcs per pallet

ABSOLUTE MAXIMUM RATINGS

Operating Temperature (min to max, °F/°C)	-40 to 194°F / -40 to +90°C
Storage Temperature (min to max, °F/°C)	-40 to 194°F / -40 to +90°C

IV CURVES

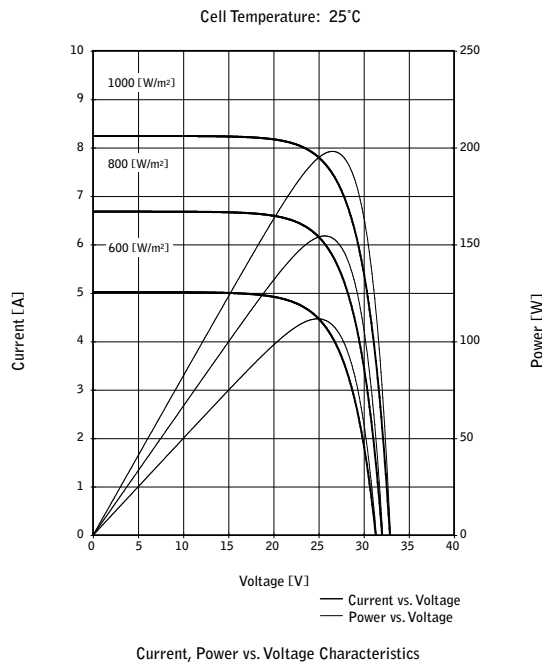

DIMENSIONS

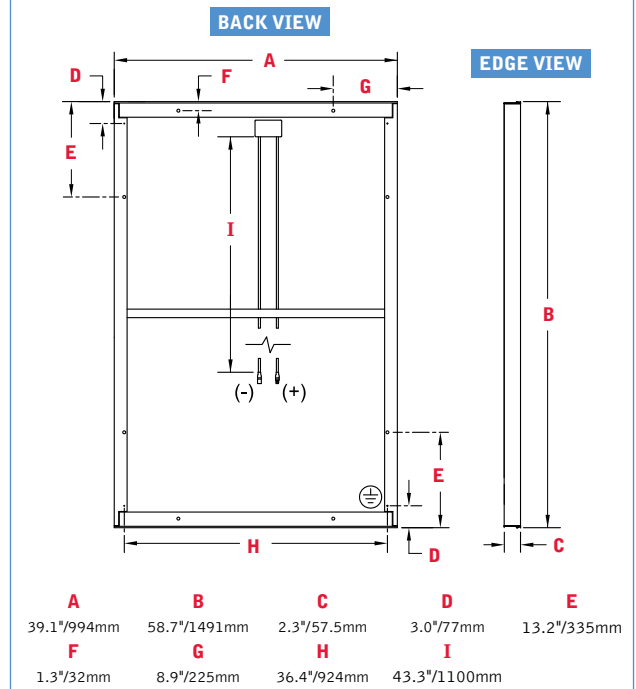

Design and specifications are subject to change without notice.

Sharp is a registered trademark of Sharp Corporation. All other trademarks are property of their respective owners.
 Sharp takes no responsibility for any defects that may occur in equipment using any Sharp devices.
 Contact Sharp to obtain the latest product manuals before using any Sharp device.

